

RS-232 DATA COMMUNICATIONS WITH THE TANDY COLOR COMPUTER

By

Tom Gunnison

© 1998

DISCLAIMER

These plans and software are provided "as is" with no guarantee of fitness for the purpose either explicit or implied. I disclaim any responsibility for losses incurred through the use of these plans. By using these plans you are deemed to have accepted these conditions of use.

RS-232 DATA COMMUNICATIONS WITH THE TANDY COLOR COMPUTER

TABLE OF CONTENTS

I. INTRODUCTION	6
A. Data Communication Systems	6
B. Serial Data Transmission	7
II. THE RS-232 INTERFACE	9
A. Electrical Signal Characteristics	9
B. Mechanical Characteristics	10
C. Functional Description of the Signals.....	11
III. THE COLOR COMPUTER'S RS-232 PORT	12
A. Transmitting Data from the Color Computer's RS-232 Port	13
B. Receiving Data through the Color Computer's RS-232 Port	13
IV. THE 6551 ASYNCHRONOUS COMMUNICATIONS INTERFACE ADAPTER.....	13
V. A CUSTOM RS-232 INTERFACE FOR THE COLOR COMPUTER.....	15
A. The Color Computer to 6551 ACIA Interface	15
B. The 6551 ACIA to RS-232 Port Interface	17
C. Building the Interface	17
VI. USING THE RS-232 INTERFACE	19
A. Cables for the RS-232 Interface.....	19
1. RS-232 Interface to Modem	19
2. RS-232 Interface (OS-9 Host) to a Terminal	20
3. RS-232 Interface (OS-9 Host) to Color Computer Serial Interface.....	20
B. SOFTWARE FOR THE RS-232 INTERFACE.....	21
VII. CONCLUSION AND RECOMMENDATIONS.....	21

RS-232 DATA COMMUNICATIONS WITH THE TANDY COLOR COMPUTER

PREFACE

The Tandy Color Computer, first introduced in 1981, has evolved through several models; the latest is called the Color Computer 3. This computer features:

- high resolution graphics in 64 colors
- up to 512k of memory
- a new keyboard

One part of the computer that has remained the same, however, is the 'serial I/O port' or RS-232 port. This port allows the user to connect a printer or modem to the computer, but can only be used with a printer without additional software. Even with the required software, operation with a modem is not reliable. The port emulates an RS-232 interface by using software. The software must perform many timing and shifting operations, giving it the name 'bit banger'.

In 1983, Tandy released a 'Deluxe RS-232 Program Pak' which was designed to allow operation of the Color Computer with a modem. The RS-232 Pak contains a special integrated circuit to more effectively handle serial communications. The chip, called an Asynchronous Communications Interface Adapter (ACIA), overcomes problems inherent in the bit banger design. The RS-232 Pak also contains communications software in a ROM to make the computer act like a terminal for operation with a modem. The RS-232 Pak has since been discontinued, but it is possible to build your own inexpensive RS-232 interface that can be reliably used with modems and terminals.

This paper describes serial data communication basics, the RS-232 serial interface standard, the Color Computer's serial I/O port, how to build an enhanced RS-232 serial interface for the Color Computer, and how to use the new port with existing software. The Color Computer's built-in serial port can be used to drive a printer.

RS-232 DATA COMMUNICATIONS WITH THE TANDY COLOR COMPUTER

GLOSSARY

ASCII	American Standard Code for Information Interchange. A 7-bit code commonly used for character data.
ACIA	Asynchronous Communications Interface Adapter. See UART.
Asynchronous	A data transmission method where each character is individually synchronized by the use of start and stop bits.
Baud Rate	The speed of data transmission, with units of electrical transitions per second.
Bits Per Second	The speed of data transmission, with units of bits per second (BPS). Modems are typically rated in BPS rather than baud.
Carrier	An analog sine wave that is used to carry data for transmission. The carrier is at an audible frequency in modems.
Data Set	Converts digital data to an analog form, for transmission over telephone lines. Also called Data Communication Equipment (DCE). Usually a modem.
Data Terminal	A computer terminal that can communicate with other computer equipment. Also called Data Terminal Equipment (DTE).
Full-duplex	A communications system capable of simultaneous two-way transmission.
Half-duplex	A communications system capable of transmission in both directions, but in only one direction at a time.
Host system	A computer system to which additional terminals can be connected for timesharing of resources.
Mark	A logic one. A mark corresponds to a voltage level of -5 to -25 volts for an RS-232 transmitter.
Modem	MODulator/DEMODulator. A type of DCE that converts digital signals to analog signals and vice-versa, for transmission of data over a telephone circuit.
Null modem	A cable that connects DTE to DTE.
OS-9	A mutli-tasking, multi-user operating system developed for Motorola 6809 microprocessor based computers.
Parity bit	A bit that may follow the data bits in a serial stream. Used for checking data integrity.

RS-232 DATA COMMUNICATIONS WITH THE TANDY COLOR COMPUTER

RS-232	Recommended Standard #232 from the Electronics Industries Association. A popular interface between DTE and DCE. It is also used between DTE and other DTE, and DTE and printers.
Serial transmission	A method of data transfer where the bits travel one-by-one over a single wire.
Space	A logic zero. A space corresponds to a voltage level of +5 to +25 volts for an RS-232 transmitter.
Start bit	The first bit transmitted in the asynchronous transmission of data to synchronize the receiver.
Stop bit	The last bit(s) transmitted in the asynchronous transmission of data to return the circuit to an idle state.
TTL	Transistor-Transistor-Logic. A digital logic family that operates from a +5 volt power supply.
UART	Universal Asynchronous Receiver Transmitter. A device which performs asynchronous communication functions by converting parallel digital data from a DTE into serial data and vice-versa.

RS-232 DATA COMMUNICATIONS WITH THE TANDY COLOR COMPUTER

I. INTRODUCTION

This paper describes RS-232 data communications as related to the Tandy Color Computer.

First, a discussion of basic data communication systems is covered. Important aspects of the RS-232 interface standard are explained. Details of a special integrated circuit that functions as the main component of an RS-232 interface is explained. Finally, a custom RS-232 interface design for the Color Computer is presented.

Enough information, including a schematic and parts list, is provided to allow a reader, with experience in electronics, to build and use the interface. Several terminal programs that will function with the interface are listed.

A. Data Communication Systems

A data communications system can be described in terms of three components: the transmitter, the transmission path, and the receiver. In a two-way system, each end has a transmitter and a receiver. The transmission path could be a telephone line. Figure 1 shows a basic data communications system, consisting of seven main components:

1. The Data Terminal Equipment (DTE) at point A.
2. The interface between the DTE and the Data Communication Equipment (DCE).
3. The DCE at point A.
4. The transmission channel between points A and B.
5. The DCE at point B.
6. The DCE to DTE interface at point B.
7. The DTE at point B.

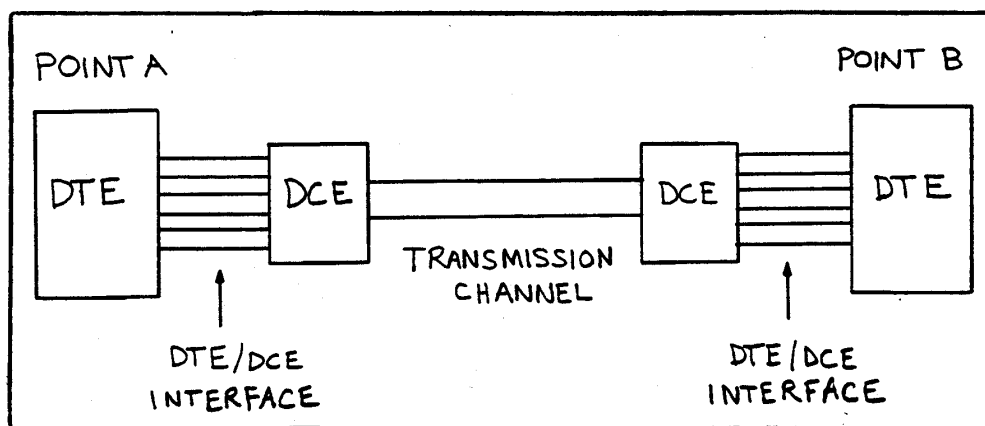

Figure 1: Block Diagram of a Data Communications System

The DTE at Point A is typically a computer terminal. The DCE is a modem. The transmission channel is usually a telephone line. The remaining part is the interface between the DTE and DCE. This is where the RS-232 interface fits in. The interface transfers data between the DTE and the DCE. Before the RS-232 interface is explained, serial data transmission will be discussed.

RS-232 DATA COMMUNICATIONS WITH THE TANDY COLOR COMPUTER

B. Serial Data Transmission

Data can be transmitted from one device to another in either parallel or serial form.

In parallel transmission, each bit is sent over a separate wire. That means for byte length data, eight wires are needed. Additional wires are necessary to indicate when the bits are ready to be read, and for power and ground.

In serial transmission, all of the bits move one-by-one on a single wire.

Parallel transmission of data is faster because an entire byte of data can be sent at once, but it takes more wires. The distance over which parallel data can be transferred is limited. For these reasons serial transmission systems are more widely used for connecting computers to terminals and modems.

Because the data in a serial system moves one bit at a time over one wire, it is necessary to have the receiver and transmitter know how fast the bits will be travelling. Thus, the specific timing "frequency" must be the same on the transmitting and receiving ends. The transmitting speed is specified by the baud rate, which is the number of signaling changes per second. A 300 baud modem's signal changes state 300 times each second, while a 600 baud modem's signal changes state 600 times per second.

At higher speeds, it is possible to encode more than one bit in each electrical change. 600 baud may allow 2,400 bits to be sent each second. At high data transfer speeds, therefore, data transmission rates are usually expressed in bits per second (BPS) rather than baud. For example, a 9,600 bps modem may operate at only 2,400 baud.

There are two types of serial communication systems in use today: synchronous and asynchronous. In synchronous communications, data is sent by blocks of many bytes which are synchronized with special characters. This method of data transmission is, however, seldom used for small computer applications. In asynchronous serial communications, a start bit is used to tell the receiver that data will be coming. When the receiver detects a start bit, it knows that data bits will follow. The data can be in any form as long as the sender and receiver know how many bits make up a piece of data. The data could be 5, 6, 7, or 8 bits. For character data, it is normally 7 bits using the American Standard Code for Information Interchange (ASCII) format.

After the data bits are sent, a parity bit may be sent. Parity is used as an error checking scheme. After the parity bit, 1, 1.5, or 2 stop bits are sent. Stop bits are used to return the transmission line to an idle state and give the computer time to process the received data. The start and stop bits are called framing bits because they surround the data being sent.

In typical asynchronous communication, 10 bits are required per character, which translates to 30 characters per second (cps) at 300 baud. For slow rates (below 1,200 baud), you can divide the bits per second by 10 to see how many characters per second are sent.

RS-232 DATA COMMUNICATIONS WITH THE TANDY COLOR COMPUTER

In summary, the transmitting DTE and the receiving DTE must both be aware of the following settings for proper serial communications:

1. The baud rate must be the same at both ends.
2. The number of data bits must be known by both ends.
3. Both ends must know if parity is being used, and what type.
4. The number of stop bits must be known by both ends.

Figure 2 shows how the ASCII letter K is transmitted with even parity and two top bits. Note that the least significant bit goes first, followed by bit 1, ect.

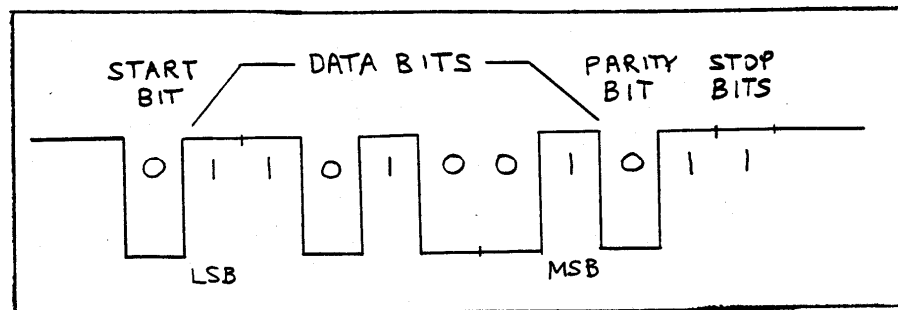

Figure 2: Serial Transfer of ASCII "K"

Several types of errors can occur when transmitting data serially:

- Framing Errors
- Overrun Errors
- Parity Errors

A **framing error** occurs when the computer receives a start bit, assembles the data bits, and then does not see a stop bit at the end.

An **overrun error** occurs when a character is received, and before the computer is able to process it, another arrives right on top of it.

If the transmitter keeps track of the number of ones in the character being transmitted, it can set the parity bit so the total number of ones is even (even parity) or odd (odd parity). The receiver keeps track of the parity to determine if the transmission was received in error (**parity error**). Parity is only useful in detecting single-bit errors. If more than one bit is affected, parity might not detect the error.

RS-232 DATA COMMUNICATIONS WITH THE TANDY COLOR COMPUTER

II. THE RS-232 INTERFACE

The most popular way to connect DTE to DCE for serial communications is with the RS-232 standard developed in 1969 by the Electronics Industries Association (EIA). RS-232 stands for 'Recommended Standard number 232'. When the 232 is followed by a letter, the letter is the revision. The most recent version of the standard is RS-232D.

The official title of the RS-232 standard is:

Interface Between Data Terminal Equipment and Data Communications Equipment
Employing Serial Binary Data Interchange.

The RS-232 standard is broken down into four sections: electrical signal characteristics, mechanical characteristics, functional description of the signals, and standard interfaces for selected communication system configurations. This paper will cover computer to modem and computer to terminal applications only.

A. Electrical Signal Characteristics

An RS-232 transmitter uses voltages from +5 to +15 for a logic 0 or space, and a voltage from -5 to -15 for a logic 1 or mark. To produce these voltages, a +/- 12 volt power supply is used.

An RS-232 receiver recognizes voltages above +3 volts as spaces, and below -3 volts as marks. It should be noted that these voltages are negative logic and are only true for the transmit and receive lines.

The other RS-232 signals use a positive logic; a positive voltage corresponds to a logic 1, and a negative voltage represents a logic 0. The RS-232 standard is thus a voltage level standard.

RS-232 cables have a maximum length limitation of about 50 feet at maximum baud rate. This is to keep the capacitance between wires below 2500 picofarads. As capacitance increases above 2500 pF, transmission quality becomes reduced.

RS-232 DATA COMMUNICATIONS WITH THE TANDY COLOR COMPUTER

B. Mechanical Characteristics

The RS-232 standard specifies a 25 pin connector for routing its signals. The DB-25 connector is commonly used for RS-232 connections. Four pins are unassigned. Many RS-232 applications use only 9 signals, so some manufacturers use a 9 pin connector. A pinout of the DB-25 connector is shown in Figure 3.

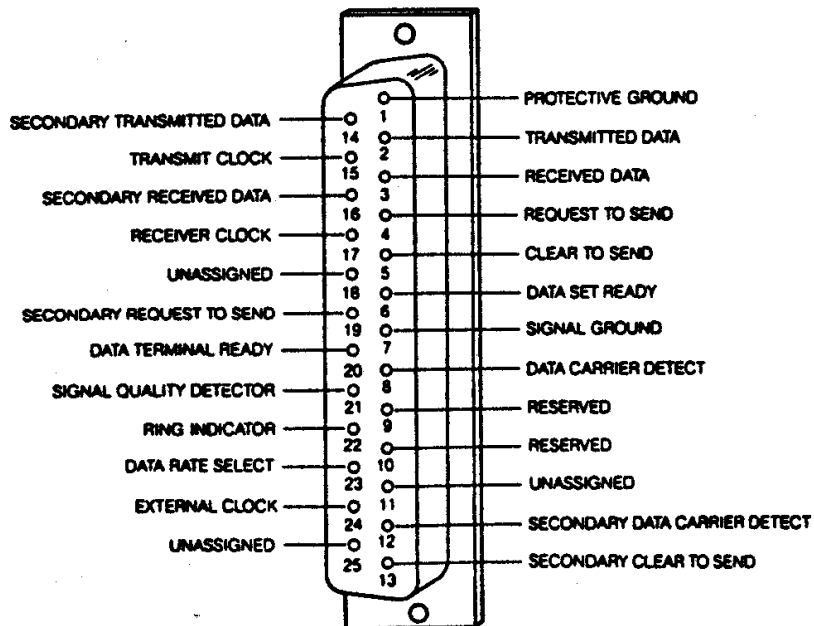

Figure 3: Pinout Specifications of the RS-232 Interface

[From G. Friend et al., Understanding Data Communications (Indianapolis, IN:Howard Sams, 1986), 4-14.]

RS-232 DATA COMMUNICATIONS WITH THE TANDY COLOR COMPUTER

C. Functional Description of the Signals

The RS-232 standard specifies 21 signals of which only nine are commonly used. For more specific information, refer to the RS-232 standard from the EIA. Table I shows the pin numbers as specified by the standard, the signal description, common abbreviations for the signals, and where the signals originate.

Pin #	Signal Description	Common Abbreviation	Source
1	Protective Ground	GND	-
2	Transmitted Data	TxD	DTE
3	Received Data	RxD	DCE
4	Request to Send	RTS	DTE
5	Clear to Send	CTS	DCE
6	Data Set Ready	DSR	DCE
7	Signal Ground	SG	-
8	Data Carrier Detect	DCD	DCE
20	Data Terminal Ready	DTR	DTE

Table I: Commonly Used RS-232 Signals

The following is a description of the most commonly used signals in an RS-232 interface. All signal names are viewed from the DTE. This is an important point when considering the transmit and receive lines. For example: pin 2 is the transmit data line from the DTE, but to the DCE it is the receive data line.

Protective Ground (GND) This pin is the protective ground which should be attached to the chassis. It is intended to prevent electric shock in the event of a power supply failure.

Signal Ground (SG) This is the common reference for all RS-232 signals. It must always be connected between the DTE and DCE for proper operation of the interface.

Transmit Data (TxD) The DTE transmits data from this pin. As pointed out earlier, all signals are viewed from the DTE.

Receive Data (RxD) The DTE receives data on this line. The DCE transmits data on this line.

Request to Send (RTS) The DTE generates this signal when it wants to send data. It can also be used to enable the modem's carrier. When the carrier is enabled, the modem asserts CTS. Because the RTS and CTS signals work together, they are called handshaking signals.

RS-232 DATA COMMUNICATIONS WITH THE TANDY COLOR COMPUTER

Clear to Send (CTS)

The DCE generates this signal when it is ready to receive data from the DTE. It is normally activated after the DCE receives a RTS from the DTE. The DCE must then keep CTS active until the DTE drops RTS.

Data Set Ready (DSR)

The DCE generates this signal when it is powered up and ready. This could also be called 'modem ready'.

Data Terminal Ready (DTR)

The DTE generates this when it is powered up and ready. This signal is sometimes used to reset the modem, which effectively hangs up the phone. Modems will not work without DTR being present.

Data Carrier Detect (DCD)

The DCE generates this signal when it is receiving a carrier from another modem. The DTE can check this signal to determine if a caller is present. The terminal can also reset itself when DCD is lost. Most terminals will not transmit or receive data without the presence of DCD.

III. THE COLOR COMPUTER'S RS-232 PORT

The RS-232 port on the back of the Color Computer has four connections: Receive Data, Transmit Data, Carrier Detect and ground. These lines are actually connected through some RS-232 to TTL level shifters to a Peripheral Interface Adapter (PIA). The PIA is a parallel I/O port that is controlled by the microprocessor. This means that everything the serial port does is under control of the PIA, which must be controlled by the microprocessor.

It will be shown in the following sections that the Color Computer's RS-232 port is limited to low baud rates when it is used with a modem. The limitations are most notable under full-duplex operation.

Figure 4 shows the pinout of the Color Computer's RS-232 port, as viewed from the back of the computer. The connector is a 4-pin DIN jack.

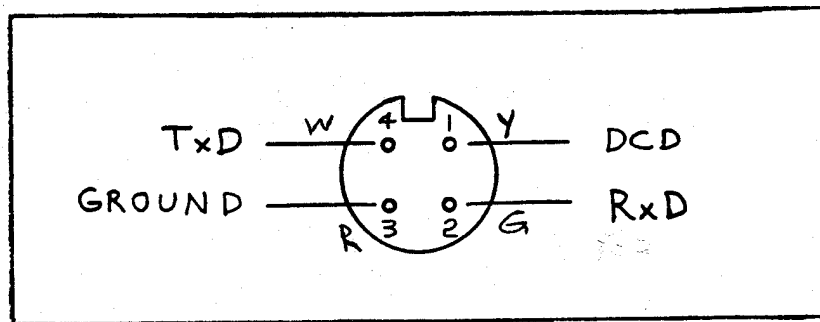

Figure 4: Pin-out of the Color Computer's RS-232 Interface

RS-232 DATA COMMUNICATIONS WITH THE TANDY COLOR COMPUTER

A. Transmitting Data from the Color Computer's RS-232 Port

To transmit a character, the bit in the PIA that is tied to the transmit line must be toggled to send a start bit. The microprocessor must then go through a timed software loop to ensure that the start bit has the proper duration for the specified baud rate. Then, the processor must shift through the character to be transmitted in reverse order, sending and timing one bit at a time. Finally, the stop bit is sent. This is intensive work for the microprocessor. Since timing is done by software loops, the processor may not be interrupted by anything while in these loops. If it were interrupted, data would be lost. For this reason, interrupts are locked out by the software while transmitting a character. This is not acceptable when using a multi-tasking operating system like OS-9, which relies on interrupts for task switching.

B. Receiving Data through the Color Computer's RS-232 Port

The problems associated with transmitting characters from the serial port are compounded by the method used in receiving characters. The computer knows that a character will be arriving when it sees a start bit. To ensure that it will see a start bit, the computer must keep an eye on the Receive Data line. If it doesn't check often enough, or if the baud rate is relatively fast, it may see the start bit late, miss it altogether, or mistakenly see a low data bit as a start bit. Since there is no way to signal the arrival of data with an interrupt, the port must be continually checked. This requires a lot of microprocessor overhead which prevents the computer from doing anything else - again a problem with a multi-tasking system.

IV. THE 6551 ASYNCHRONOUS COMMUNICATIONS INTERFACE ADAPTER

To ease the burden on the microprocessor during serial communications, the Universal Asynchronous Receiver Transmitter (UART) was developed. UARTs are integrated circuits that handle most of the tasks necessary for serial I/O. Many different UARTs are available from a variety of manufacturers. The UART to be used in this project is called an Asynchronous Communications Interface Adapter (ACIA) by the manufacturer. The ACIA is designated a 6551, and is produced by several electronics manufacturers.

A. Operation of the 6551 ACIA

The 6551 ACIA performs two basic functions for the computer:

1. It converts a parallel 8-bit character to a serial bit stream for transmission.
2. It converts a serial bit stream to a parallel 8-bit character for the computer to receive.

RS-232 DATA COMMUNICATIONS WITH THE TANDY COLOR COMPUTER

The 6551 ACIA actually performs many more tasks than parallel to serial and serial to parallel conversion. The ACIA contains a total of five registers that the computer interacts with. The following is a description of each register:

1. Transmit Register - an 8-bit temporary storage area for data to be transmitted.
2. Receive Register - an 8-bit temporary storage area for data that was received.
3. The Command Register - controls parity, echo mode, transmitter and receiver interrupt control, and the states of RTS and DTR.
4. The Control Register - controls the number of stop bits, word length, baud rate, and clock source.
5. The Status Register - indicates the states of the DSR and DCD lines, transmitter and receiver registers, overrun, framing, and parity error conditions, and interrupt status.

As can be seen, the ACIA is a relatively complex device but it is also very flexible. The following sections should simplify what the ACIA does for specific operations.

The 6551 ACIA performs the following tasks to transmit a character:

1. Handles the generation of the start bit, data bits, parity bit, and stop bit(s).
2. Handles all timing associated with sending the data at the specified baud rate.
3. Notifies the computer when the character has been sent, by setting a status bit and sending an interrupt if enabled.

The 6551 ACIA performs the following tasks to receive a character:

1. It watches for a start bit from the Receive Data line.
2. When it receives a start bit, it assembles the data into a parallel byte for the computer.
3. It checks parity and, if incorrect, sets a status bit.
4. It checks for framing and overrun errors, and if any are detected, sets a status bit.
5. Notifies the computer when the character has been received, by setting a status bit and sending an interrupt if enabled.

The following RS-232 signals can be monitored and controlled by the ACIA:

1. DSR and DCD - If DSR or DCD change state, the ACIA will notify the computer by setting a status bit and sending an interrupt if enabled.
2. RTS and CTS - The transmitter is enabled when CTS is low, and disabled when CTS is high. RTS can be controlled by the computer.
3. DTR - Can be set or cleared by the computer to indicate that the terminal is ready, or to reset the modem.

Detailed information on programming and controlling the 6551 ACIA is contained in manufacturer's data sheets. It is not necessary to know how to program the ACIA because there is software available that can be used with the design presented in the next section.

RS-232 DATA COMMUNICATIONS WITH THE TANDY COLOR COMPUTER

V. A CUSTOM RS-232 INTERFACE FOR THE COLOR COMPUTER

The following figure is a schematic of my RS-232 Interface that can be plugged into the Color Computer's Multi-Pak Interface. The circuit consists of two sections:

1. The Color Computer to 6551 ACIA Interface.
2. The 6551 ACIA to RS-232 Port Interface.

A. The Color Computer to 6551 ACIA Interface

The 6551 ACIA interacts with the Color Computer through the data, address, and control busses. The data bus is directly connected for data transfer. The control bus lines needed are: the E clock for clocking data transfers, the RESET line for resetting the ACIA, the R/W line for controlling the direction of data transfer, and the CART line to pass interrupts to the computer from the ACIA. The CART interrupt line is pulled up by R1 to prevent interrupts when the ACIA is inactive. The computer's address bus is used to map the ACIA at addresses \$FF68-\$FF6B for compatibility with existing software drivers.

RS-232 DATA COMMUNICATIONS WITH THE TANDY COLOR COMPUTER

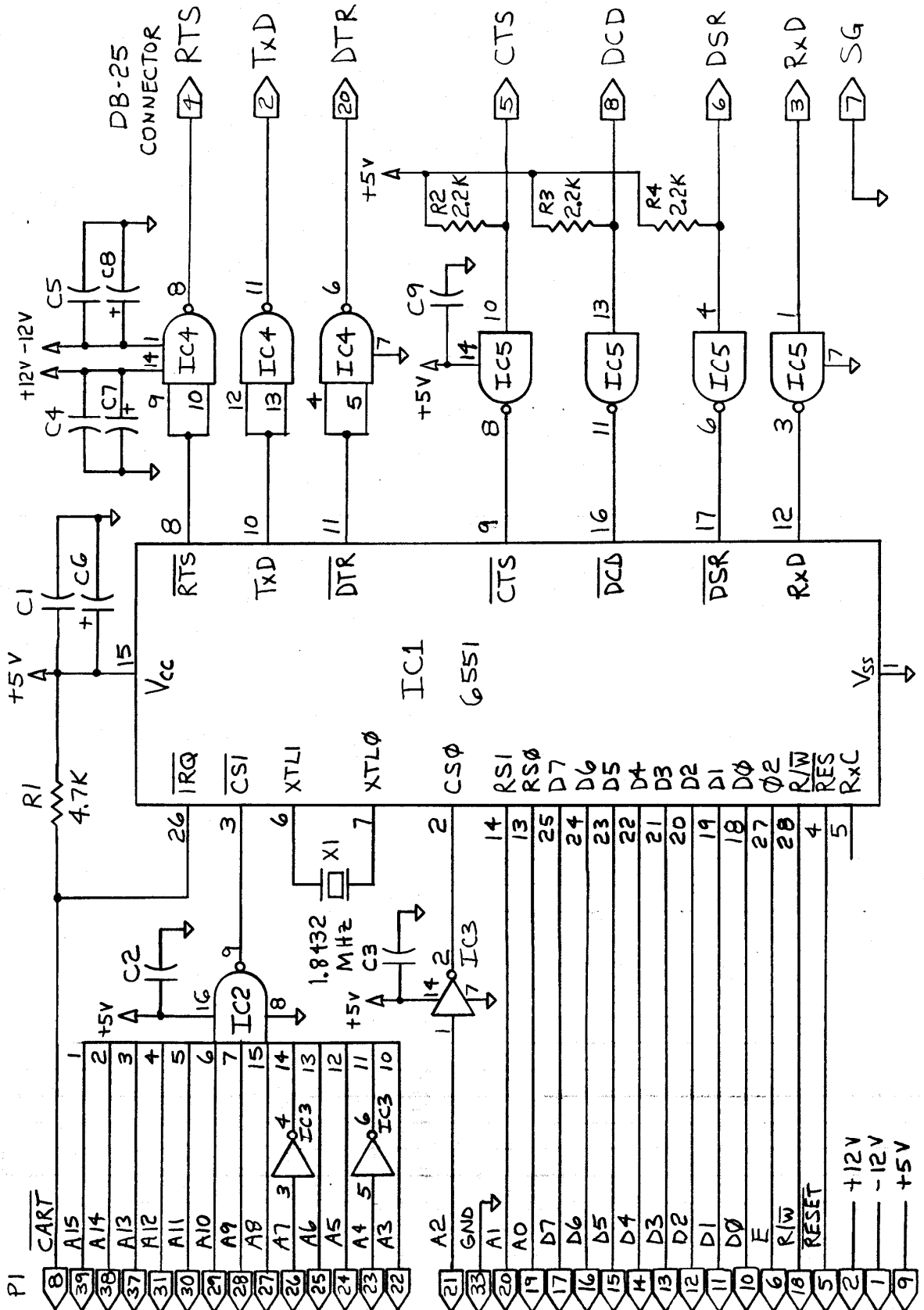

FIGURE 5: SCHEMATIC, RS-232 INTERFACE

RS-232 DATA COMMUNICATIONS WITH THE TANDY COLOR COMPUTER

The address decoder is comprised of IC2 and IC3. The ACIA is selected when A3, A5, A6, and A8-A15 are high, and A4, A7, and A2 are low. The lines A0 and A1 are register select lines to select the various ACIA internal registers. Power for the interface is supplied from the Multi-Pak Interface. Voltages required include: +5 volts, +12 volts, and -12 volts.

B. The 6551 ACIA to RS-232 Port Interface

The main components required are IC4 and IC5. IC4 is an RS-232 line driver. It performs the voltage level conversions from TTL level to RS-232 levels. IC5 is an RS-232 line receiver. It performs the voltage level conversion from RS-232 levels to TTL levels. Pull-up resistors R2-R4 will ensure operation of the interface even if CTS, DCD, or DSR are not available. One last important connection is the 1.8432 MHz crystal. The crystal is used by the ACIA to derive the various baud rates.

C. Building the Interface

The circuit can be built on a proto-board with a 40-pin (20 on each side) edge connector. The pin to pin spacing must be 0.1 inch. The circuit can be wire wrapped or wired point-to-point. The recommended proto-board has plated through holes for point to point wiring, as well as power and ground busses. Figure 6 shows the pin numbers of the edge connector and the computer's expansion connector. The schematic refers to the edge connector as P1.

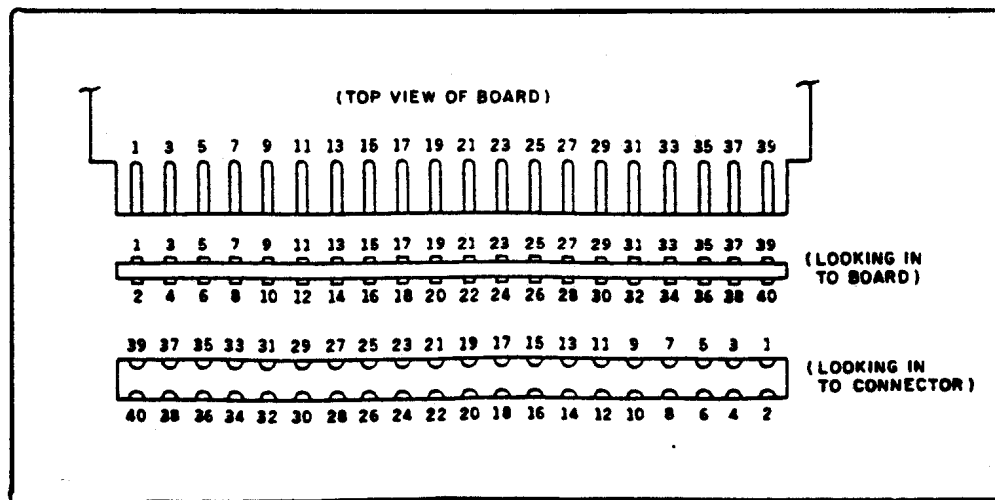

Figure 6: Proto-board and Multi-Pak Port Pin Designations

The board and other parts needed for the project are shown in Table II. All parts can be obtained from Internet electronics dealers such as:

<http://www.digikey.com>

RS-232 DATA COMMUNICATIONS WITH THE TANDY COLOR COMPUTER

<u>Item</u>	<u>Part No.</u>	<u>Description</u>
IC1	6551	Asynch. Comm. Interface Adapter
IC2	74LS133	13 Input NAND Gate
IC3	74LS04	Hex Inverter
IC4	LM1488	RS-232 Line Driver
IC5	LM1489	RS-232 Line Receiver
X1		1.8432 MHz Crystal
R1		4.7K Ohm, 1/4W, 20% Resistor
R2-R4		10K Ohm, 1/4W, 20% Resistor
C1-C5,C9		0.1uF Disc Capacitor, 25V
C6-C8		10uF Electrolytic Capacitor, 25V

Miscellaneous Parts

1	28 pin DIP Socket
1	16 pin DIP Socket
2	14 pin DIP Sockets

Proto-board
Female DB-25 connector
Solder
Connection wire

Table II: RS-232 Interface Parts List

The proto-board used to be available from. It may be possible to find a similar board that can be used.

Speech Systems
38W255 Deerpath Rd.
Batavia, IL 60501

RS-232 DATA COMMUNICATIONS WITH THE TANDY COLOR COMPUTER

VI. USING THE RS-232 INTERFACE

In order to use the RS-232 interface with existing software, it should be plugged into slot one of the Multi-Pak Interface. A cable is required to connect the interface with either a modem or another terminal. When the interface is used with another terminal, OS-9 is used as the 'host' system. The following configurations could be used with the RS-232 interface:

1. RS-232 Interface to a Modem
2. RS-232 Interface (OS-9 Host) to a Terminal
3. RS-232 Interface (OS-9 Host) to Color Computer Serial Interface.

The following sections explain how to make appropriate cable connections for each of the three applications listed above, and how to use the interface with existing software.

A. Cables for the RS-232 Interface

1. RS-232 Interface to Modem

The simplest and probably most common way to use the interface is with a modem. A cable for this purpose can be purchased from Radio Shack or other computer equipment dealers. The cable consists of a 25-wire ribbon cable with a DB-25 connector at each end. The following table shows what connections are made.

<u>RS-232 Interface</u>	<u>Modem</u>	<u>Function</u>
Pin 1	Pin 1	GND
Pin 2	Pin 2	Txd
Pin 3	Pin 3	RxD
Pin 4	Pin 4	RTS
Pin 5	Pin 5	CTS
Pin 6	Pin 6	DSR
Pin 7	Pin 7	SG
Pin 8	Pin 8	CD
Pin 20	Pin 20	DTR

Table III: RS-232 Interface to Modem Wiring

RS-232 DATA COMMUNICATIONS WITH THE TANDY COLOR COMPUTER

2. RS-232 Interface (OS-9 Host) to a Terminal

A 'null modem' cable is needed for this application. The cable has the transmit and receive connections reversed at the terminal end. This cable connects DTE to DTE. Null modem cables can be purchased at Radio Shack or other computer dealers. The diagram shows pins 5, 6, and 8 connected to pin 20 of the opposite connector.

<u>RS-232 Interface</u>	<u>Terminal</u>
Pin 1 -----	Pin 1
Pin 2 -----	Pin 3
Pin 3 -----	Pin 2
Pin 4 not used	Pin 4
Pin 5 !-----	Pin 20
Pin 6 !	! Pin 5
Pin 8 !	! Pin 6
Pin 20 -----	! Pin 8
Pin 7 -----	Pin 7

Table IV: RS-232 Interface to Terminal Wiring

3. RS-232 Interface (OS-9 Host) to Color Computer Serial Interface

This application requires a null modem cable. The cable cannot be purchased, but can be easily made. The Color Computer's serial interface uses a 4-pin DIN plug. The pin-out is shown in Figure 4. The plug can be purchased at Radio Shack stores. A DB-25 connector for the other end of the cable can also be purchased at Radio Shack. The following table shows the connections to be made.

<u>RS-232 Interface</u>	<u>Color Computer Serial</u>
Pin 2 -----	Pin 2
Pin 3 -----	Pin 4
Pin 4	not used
Pin 5	not used
Pin 6	not used
Pin 7 -----	Pin 3
Pin 8	not used
Pin 20	not used

Table V: RS-232 Interface to Color Computer Serial Interface Wiring

RS-232 DATA COMMUNICATIONS WITH THE TANDY COLOR COMPUTER

B. SOFTWARE FOR THE RS-232 INTERFACE

Several terminal programs are available that can be used with the RS-232 interface. The interface can be used from RSDOS or OS-9. Some terminal programs that run under RSDOS are:

1. MikeyTerm (MTERM)
2. Greg-E-Term (GETERM)
3. Ultimaterm

These programs are available from:

<ftp://www.rtsi.com/RSDOS/TELECOM>

All communication parameters can be controlled from within the programs. They feature Xmodem uploading and downloading.

Under OS-9, a public domain program called **Xcom9** can be used. This program works with the device driver ACIAPAK and the device descriptor T2 that come with OS-9. Communication parameters are controlled by the device descriptor T2 which can be changed with the XMODE command from OS-9. Other programs include **OSTerm** and **Supercomm**.

These programs are available from:

ftp://www.rtsi.com/OS9/OS9_6X09/TELECOM

VII. CONCLUSION AND RECOMMENDATIONS

The RS-232 interface described here can greatly increase the capability of the Tandy Color Computer. With it, a modem can be connected for reliable data communications at up to 14.4k BPS.

The RS-232 interface could also be used with another terminal, using the OS-9 operating system, for an efficient multi-user system. In either of these configurations, the Color Computer's built-in serial I/O port is left open for operation with a printer.

The low cost and ease of building the RS-232 interface makes the project a viable method to increase the communications capability of the Color Computer.

<mailto:tgmaxx@gmail.com>

RS-232 DATA COMMUNICATIONS WITH THE TANDY COLOR COMPUTER

REFERENCES

Campbell, Joe. 1984. The RS-232 Solution.
Berkeley, CA.: Sybex.

Chatham, Dale. 1981. Color Computer Technical Reference Manual.
Fort Worth, Texas: Tandy Corporation.

Friend, George E. et al. 1986. Understanding Data Communications.
Indianapolis, IN.: Howard Sams & Company.

Leibson, Steve. 1982. The Input/Output Primer, Part 4. Byte.
May 1982:202-219.

Rockwell Corporation. 1984. R6551 Asynchronous Communications Interface
Adapter.
Document No. 29651N90.

Witten, Ian H. 1983. Welcome to the Standards Jungle. Byte.
February 1983:146-178.